

EASYCLEAR 3000

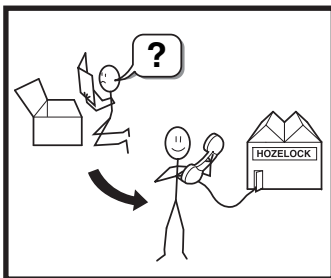

BEAB
Approved

RoHS
COMPLIANT
2002/95/EC



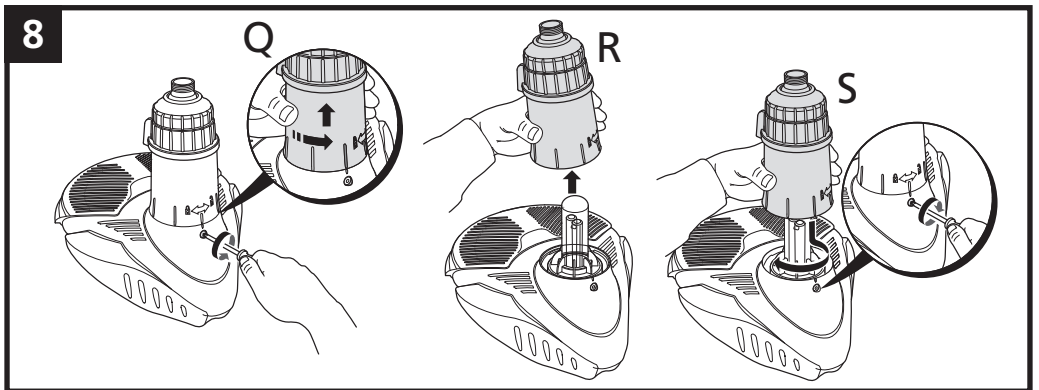
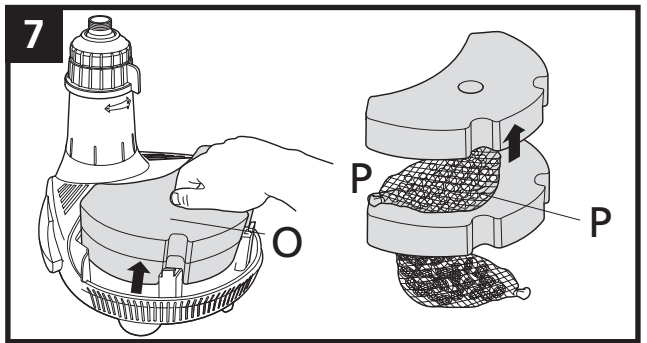
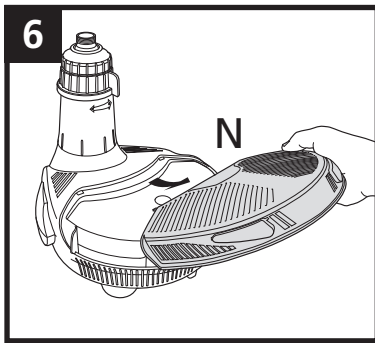
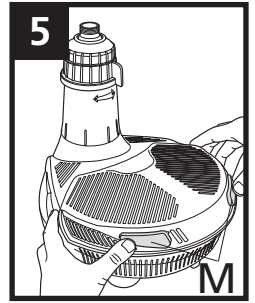
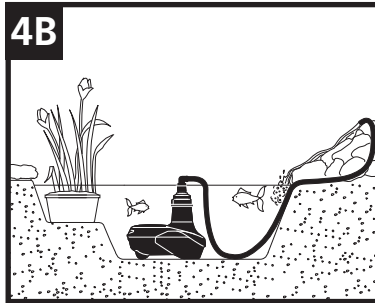
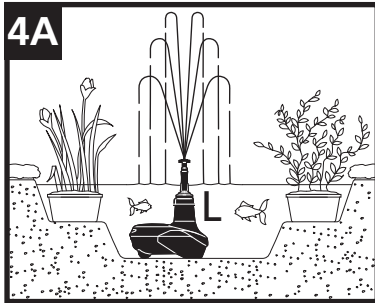
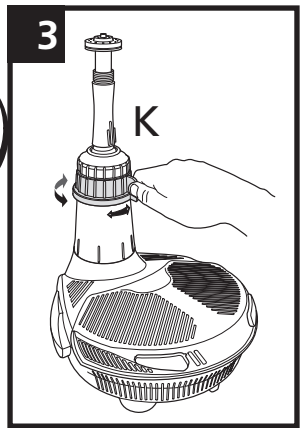
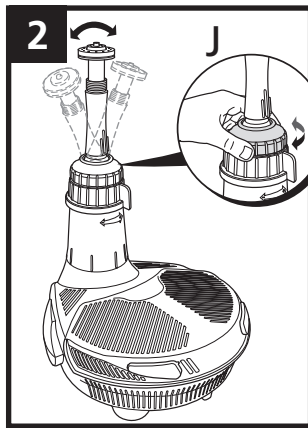
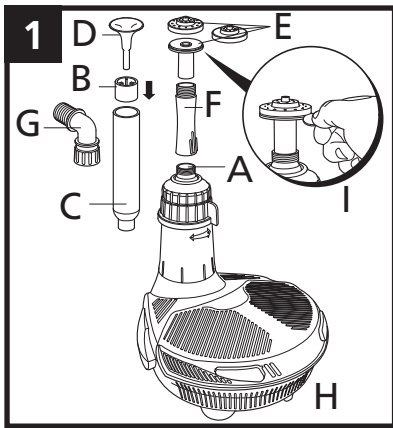

9

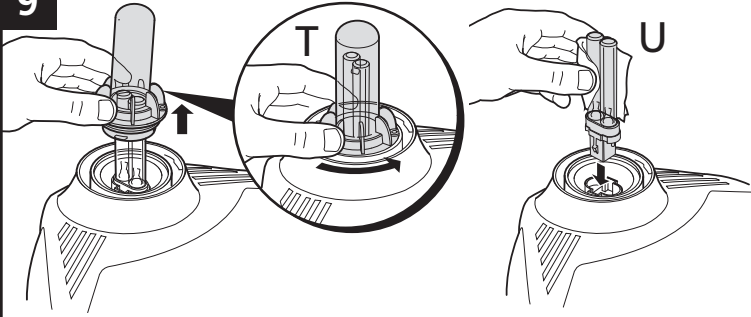

10

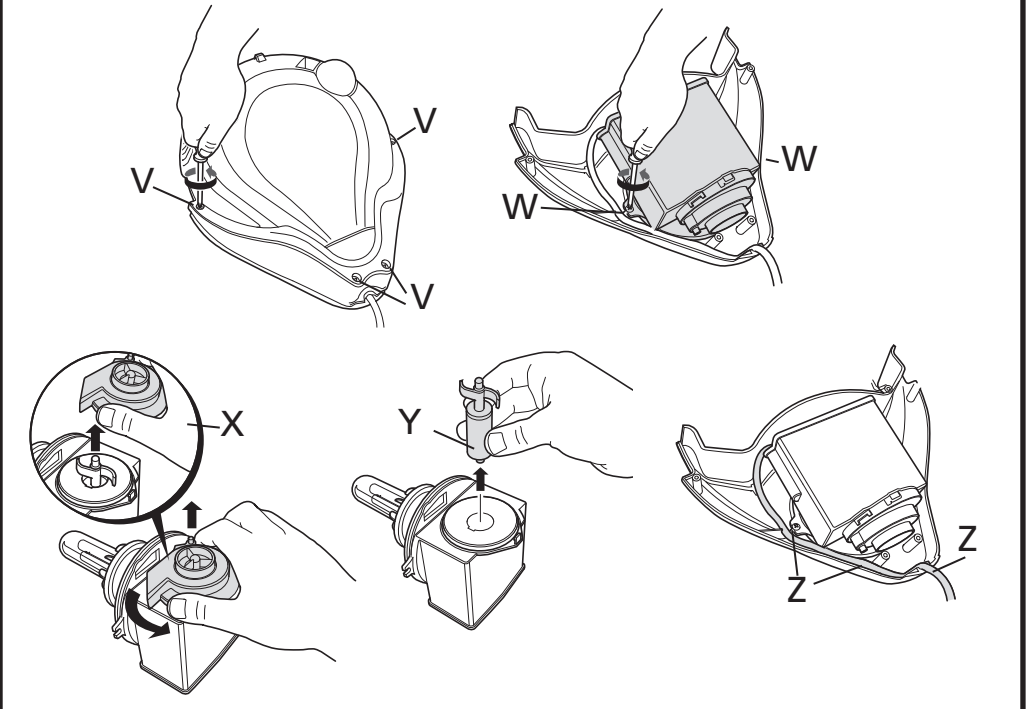

10A

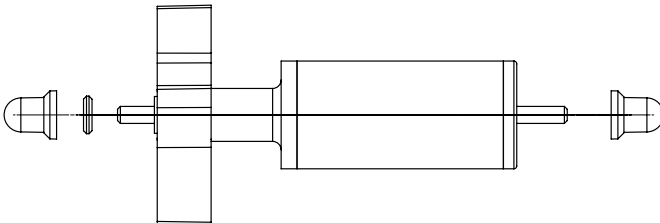

 **INSTALLATION AND OPERATING INSTRUCTIONS. READ INSTRUCTIONS CAREFULLY BEFORE ATTEMPTING INSTALLATION. KEEP THESE INSTRUCTIONS FOR FUTURE REFERENCE.**

The Hozelock Cyprio EasyClear™ Fountain or Waterfall pump is designed for submersible use in outdoor ponds. It is an integrated unit that provides Mechanical & Biological Filtration with an Ultra Violet Clarifier, Fountain or Waterfall.

General Safety & Guidelines

The appliance is not intended for use by persons (including children) with reduced physical, sensory or mental capabilities, or lack of experience and knowledge, unless they have been given supervision or instruction concerning use of the appliance by a person responsible for their safety. Children should be supervised to ensure that they do not play with the appliance.

(Australia & NZ only) This appliance is not intended for use by young children or infirm persons unless they have been adequately supervised by a responsible person to ensure that they can use the appliance safely. Young children should be supervised to ensure that they do not play with the appliance.

Do not operate or leave the unit in freezing conditions.

Do not switch the pump on out of water! The water level should be above the UVC indicator at the ball joint (Fig 4A-L).

DO NOT OPERATE THIS UNIT WITHOUT THE OUTER CAGE ATTACHED. USING THE UNIT WITHOUT THE OUTER CAGE MAY INVALIDATE YOUR WARRANTY.

The clear tube inside the unit is made from quartz glass and care should be taken during installation and maintenance. We recommend the use of eye protection and suitable gloves.

UV Caution

The EasyClear 3000 is fitted with a 5W UVC lamp. Exposure to Ultra Violet (UV) radiation can be dangerous and cause damage to eyes and skin. Under no circumstances should any attempt be made to gain access to the lamp when the unit is switched on. When switched on, the lamp can be checked for operation by looking for a bluish glow from the ball joint outlet (Fig 1-A). Please note that this may only become visible in low light conditions.

Legislation

From 1st January 2005 installing this product in the garden is classed as 'notifiable' in the revised Building Regulations for England and Wales. The Regulations now require you to tell your local authority building control department that you intend to install this product before installation. Your local authority will let you know how you can get your installation approved.

Overload Protection

To help ensure your EasyClear's long life and to prevent damage, it is fitted with automatic thermal Overload Protection. This switches the pump or UV lamp off if either overheats. If this

occurs, switch off the power at the mains supply to the unit. If it is the pump that has activated the Overload Protection, check for the cause (it is usually debris blocking the inlet of the pump or obstructing the impeller). Remove the obstruction and wait 15 minutes for the unit to cool down and. Then switch it on again.

If it is the UV lamp that is activating the Overload Protection (pump is still running but UV lamp keeps going out after running for a short time), please contact Hozelock Consumer Services Helpline on +44 (0)121 313 1122.

NOTE: YOU MUST SWITCH OFF THE MAINS SUPPLY BEFORE THE UNIT WILL RESET.

Periods of Operation

Keep the filter working 24 hours a day. Ideally it should run all year round, but at least throughout the fish-feeding season, (i.e. until the water temperature falls below 10°C and the fish stop feeding). In winter, operating the unit will maintain a basic level of useful bacteria in the Biological Filter, and will help prevent the pond icing over. However, the unit must not be allowed to freeze. If you switch the unit off for winter, wash the unit thoroughly before resuming filtration in the spring (see 'Winter Storage'). Never feed your fish when the unit is not in use.

Electrical Safety

• ALWAYS UNPLUG OR DISCONNECT ALL APPLIANCES IN THE POND FROM THE ELECTRICITY SUPPLY BEFORE PUTTING YOUR HANDS IN THE WATER WHILST EQUIPMENT IS BEING INSTALLED, REPAIRED, MAINTAINED OR HANDLED.

- Do not use the supply cable to lift the unit, as this may cause damage. We recommend fitting a lifting cord to the hook feature on the base, when the filter is installed in deep water. (Fig 1-H).

- Check that the voltage marked on the unit corresponds to the mains supply.

- **A 10mA OR 30mA RESIDUAL CURRENT DEVICE (RCD) MUST BE FITTED TO THE MAINS SUPPLY.**

- The pump is supplied with 10m of 3 core electric cable which is permanently connected and sealed to the pump. **The supply cable cannot be replaced. If the cable is damaged, the unit should be discarded.** This product is designed to be permanently wired to the mains supply in a dry weatherproof enclosure through a Double-Pole Switched Fused Spur - (Disconnecter) to BS 3676, with a minimum contact separation of 3mm in each Pole & Fitted with a 3 or 5 Amp fuse.

- The installation must conform to the national and local wiring regulations which could include the use of plastic or metal conduit to protect the cable.

- **THIS APPLIANCE MUST BE EARTHED AND IT IS ESSENTIAL THAT THE CONNECTIONS ARE MADE USING THE FOLLOWING CODE;**



The BROWN lead should be connected to the LIVE terminal which may be marked with an 'L' or coloured brown or red. The BLUE lead should be connected to the NEUTRAL terminal which may be marked with an 'N' or

coloured blue or black. The GREEN/YELLOW lead should be connected to the EARTH terminal which may be marked with an 'E' or coloured green or green/yellow.

- If an extension cable is required, this should be connected to the end of the unit cable using a weatherproof connector. The joint must be positioned in a suitable weatherproof housing. The extension cable should be of 3 core 0.75mm² Polychloroprene rubber insulated cable (ref: HO5 RN-F) and permanently wired to the mains supply with a 3 or 5 Amp fuse.

- The unit cable (and extension cable) should be positioned and adequately protected against damage especially where contact with gardening equipment (lawn mowers, forks etc.) children and domestic animals may occur.

- **CONSULT A QUALIFIED ELECTRICIAN OR LOCAL AUTHORITY IF IN ANY DOUBT ABOUT WIRING TO THE MAINS SUPPLY.**

Installation

Position - Construct a solid and level platform on which to place the EasyClear™. The platform should be greater than 300 mm (12") below the water level. For depths between 300mm and 600mm use the fountain stem extension segments (Fig 1-F), which simply screw together, to allow the fountain to be above the water level. For general installation see Fig 4 A/B. When using the EasyClear for a waterfall the entire unit should be submersed.

Connection - Place the unit next to the pond and route the cable back to the mains supply. Ensure that you allow for

enough cable for positioning the product in the desired location in the pond.

Accessory Assembly

Bell Fountain (Fig 1).

Locate the Bell Support (B) to the Bell Main Body (C) and push fully home. Position the Bell (D) to the Body Assembly and press into the central location.

2 and 3 tier fountain display assembly (Fig 1-E).

The plastic discs that create the 2 and 3 tier water displays simply snap onto the fountain stem. Push the fountain stem into the fountain stem extension segment and screw onto the fountain outlet (Fig 1-A).

Fountain Only Operation

(Fig 4-A for general installation guide)

Please note: The product has a water by-pass to control water flow rates which means a quantity of water will always come out of the product just below the flow control. This is normal in operation.

Position the unit in the pond. The fountain angle can be adjusted to be vertical using the ball joint (Fig 2-A). The tightness of the ball joint can be adjusted (Fig 2-J)

If required, the 2-Tier Fountainhead can be used to achieve an alternative and higher display pattern than the 3-Tier.

The fountain height can be adjusted to suit your needs by rotating the Fountain Flow Adjuster. (Fig 3-K)

The Bell Fountain creates a decorative waterbell. The size of the bell can be adjusted to suit your needs by rotating the Fountain Flow Adjuster (Fig 3-K).

Waterfall Only Operation

(Fig 4-B for general installation guide)

Position the pump as previously described.

Attach a suitable length (3m maximum) of 25 mm (1") hose to the waterfall hose tail (Fig 1-G) and secure with a suitable hose clip and position the outlet end of the hose in the desired position.

Screw the waterfall hose tail to the fountain outlet of the EasyClear™ (Fig 1-A) and adjust the flow using the fountain flow adjuster, (Fig 3-K), to suit your needs.

Note: The maximum recommended waterfall height above pond level is 0.5m (Fig 4-B).

UVC Operation

The UVC will automatically switch on once the unit has been connected to the electricity supply.

The UVC lamp can be checked for operation by looking for a bluish glow from ball joint outlet (Fig 1-A). Please note that this may only become visible in low light conditions.

See Maintenance section for Lamp replacement.

Maintenance

The Hozelock Cyprio EasyClear™ has been designed to allow fast and easy maintenance. As with all pond

equipment, occasionally it will become necessary to clean or replace parts. Refer to the safety sections before attempting any maintenance.

Fountain Head (Fig 1-I)

Follow the below procedure if the fountain head is blocked:

- 1 - Place a coin or similar in the slot and gently lever off the fountain head.
- 2 - Rinse in clean water and reassemble.

Foam

Follow the below procedure if flow appears reduced:

- 1 - Release the Foam Cover by pushing the two buttons (Fig 5-M) and lift the cover (Fig 6-N).
- 2 - Remove the Foam (Fig 7-O). Note:- If the unit is out of the pond for more than 20 minutes the biological filter action may stop working.
- 3 - The Foam Cover and Base should also be rinsed.
- 4 - It may also be necessary to clean out the biomed and stones (Fig 7-P) if these have become clogged.
- 5 - Reassemble the Filter.

Quartz Tube

Follow the below procedure if your pond remains green:

- 1 - Remove the bayonet locking screw (Fig 8-Q), twist and lift the bayonet tube (Fig 8-R).
- 2 - Clean the Quartz Tube. Take extra care when handling the Quartz tube. In hard water areas, the quartz tube may become covered in limescale, which will reduce efficiency. Clean the tube with a soft cloth and a gentle de-scaler (such as vinegar and water), rinse in water before refitting.
- 3 - Reassemble the bayonet tube and

restart (Fig 8-S).

Warning! Ensure that the quartz tube is not damaged before refitting.

Lamp Replacement

Follow the below procedure if the lamp needs replacing or does not illuminate:

Change the lamp at the start of the new season. Even though the lamp still glows it may not be giving out any useful UV radiation. How well the EasyClear™ performs is related to the strength of the UV radiation produced. This will slowly decline from the day your lamp is switched on. The UVC lamp has an effective life of 12 months. You need to change the lamp when there is a significant reduction in water clarity. Make sure this is due to an expired lamp and not a badly maintained filter or a dirty/limescaled quartz sleeve. Both can greatly reduce UV transmission into the water.

- 1 - Remove the bayonet locking screw (Fig 8-Q), twist and lift the bayonet tube (Fig 8-R).
- 2 - Remove the quartz tube, rotating the plastic moulding anticlockwise and lifting up and away (Fig 9-T).
- 3 - With the lamp now accessible pull it out of the holder (Fig 9-U) and push in a new lamp.
- 4 - Reassemble the bayonet tube and restart (Fig 8-S).

Warning! Ensure that the quartz tube is assembled correctly so that it provides a completely watertight seal.

Check the condition of the two o-rings on the Quartz Tube Assembly (Fig 11-3). If these are damaged in any way or you can not guarantee a water tight seal, contact Hozelock Consumer Services.

Biological Filter

Normally, there is no need to remove the biomedica as any cleaning may kill the colonies of bacteria that make toxic waste harmless.

- 1 - Remove the foam.
- 2 - The bag of Kaldnes Biomedica (Fig 7-P) can be removed for cleaning.
- 3 - Wash in pond water.
- 4 - Reassemble the filter and restart.

Rotor Cleaning/Replacement

Follow the below procedure if the no water is being pumped or flow is reduced:

- 1 - Release the Foam Cover by pushing the two buttons (Fig 5-M) and lift the cover (Fig 6-N).
 - 2 - Remove the foam (Fig 7-O), biomedica (Fig 7-P) and stone bag.
 - 3 - Turn the unit over and remove the 4 fixing screws (Fig 10-V) and lift the base clear.
 - 4 - Remove the 2 fixing screws (Fig 10-W) and lift the Pump Assembly clear.
 - 5 - Twist the Pump Chamber anti-clockwise (Fig 10-X) and lift clear. The rotor can now be pulled out for cleaning or replacement (Fig 10-Y).
- Important! Take extra care so as to not drop any of the small components. See Fig 10A for assembly of the rotor.**
- 6 - Reassemble the pump and 2 off fixing screws (Fig 10-W).
 - 7 - Reroute the cable (Fig 10-Z).
 - 8 - Reassemble the filter, and restart.

All Year Pump Care

A quick daily check should be carried out to ensure that the pump is performing satisfactorily.

Once a week- Remove the outer casing and Fountain Head in accordance with

the general maintenance notes. Depending on pond water conditions, cleaning may be required more frequently.

Once a year- Completely disassemble the unit including the Rotor Assembly as described in the general maintenance notes, and wash all components in clean, freshwater. Replace worn or broken parts.

Winter Storage

When not in use, the unit should be removed, thoroughly washed and cleaned, dried and stored in a dry frost protected area. Always store the unit with the foam and foam cover off to ensure adequate ventilation and drying.

Spare Parts

For spares and accessories, please visit www.hozelockservice.com

Fish Stocking and Density

Under normal conditions, the EasyClear™ will support up to 72cm of fish. Introduce fish slowly over the first few weeks, up to 20% of the maximum recommended level, increasing to 50% after six months. The balance will allow for fish growth.

Clearwater Guarantee

We guarantee you Clearwater or your money back! **NOTE: IN SOME CASES IT CAN TAKE UP TO 6-8 WEEKS FOR YOUR WATER TO BECOME CLEAR.**

This guarantee runs for 12 months after purchase, provided that:

- You have followed the installation and operating instructions

- You are using equipment of the correct size and stocking level for your pond

- You consult our Helpline +44 (0)121 313 1122 early enough for any problems to be put right

- The product has been returned undamaged. A refund can only be authorised by Hozelock Cyprio and is made at the place of purchase.

3 Year Product Guarantee

If this unit, excluding the Rotor Assembly, Filter Foam & UV Lamp becomes unserviceable within 3 years of the date of purchase it will be repaired or replaced at our option free of charge, unless in our opinion it has been damaged or misused. Liability is not accepted for damage due to accident, improper installation or use.

Liability is limited to replacement of a faulty unit. This guarantee is not transferable. It does not affect your statutory rights.

To obtain the benefits of the guarantee, firstly contact Hozelock Cyprio Consumer Services who may request that the filter is sent along with proof of purchase directly to the address provided.

DAMAGE CAUSED BY RUNNING THE EASYCLEAR OUT OF WATER OR BY FROST INVALIDATES THE GUARANTEE.

Fault Finding

Please read the safety sections of these instructions before carrying out any remedial action on the EasyClear! It may also be necessary to refer to the maintenance section of these instructions.

LOW FLOW FROM PUMP	<ul style="list-style-type: none">a – The foams may be blocked and require cleaningb - Ensure the outer cage is clean.c - Clear any blockages and adjust the flow controls.d - Check white flap inside pump chamber moves freely.e - Ensure rotor is clean and moves freely.
POOR FOUNTAIN DISPLAY	<ul style="list-style-type: none">a – As aboveb - Clean the Fountain Head.
UV LAMP NOT WORKING	<ul style="list-style-type: none">a - Check power supply is on.b - Check fuse, RCD and wiring.c - Replace the lamp.d - The Overload Protection may have operated – see Overload Protection section.
PUMP NOT WORKING	<ul style="list-style-type: none">a - Check power supply is on.b - Check fuse, RCD and wiring.c- Check the rotor is not blockedd - The Overload Protection may have operated – see Overload Protection section.e - Ensure the outer cage is clean.f – Check for water ingress in lamp area



Hozelock Ltd.
Midpoint Park,
Birmingham B76 1AB. England

Tel: +44 (0)121 313 1122

info@hozelock.com

www.hozelock.com

33854-005



This marking indicates that this product should not be disposed with other household wastes throughout the EU. To prevent possible harm to the environment or human health from uncontrolled waste disposal, recycle it responsibly to promote the sustainable reuse of material resources. To return your used device, please use the return and collection systems or contact the retailer where the product was purchased. They can take this product for environmental safe recycling.